

**PLANTA**  
ESCALA 1:50

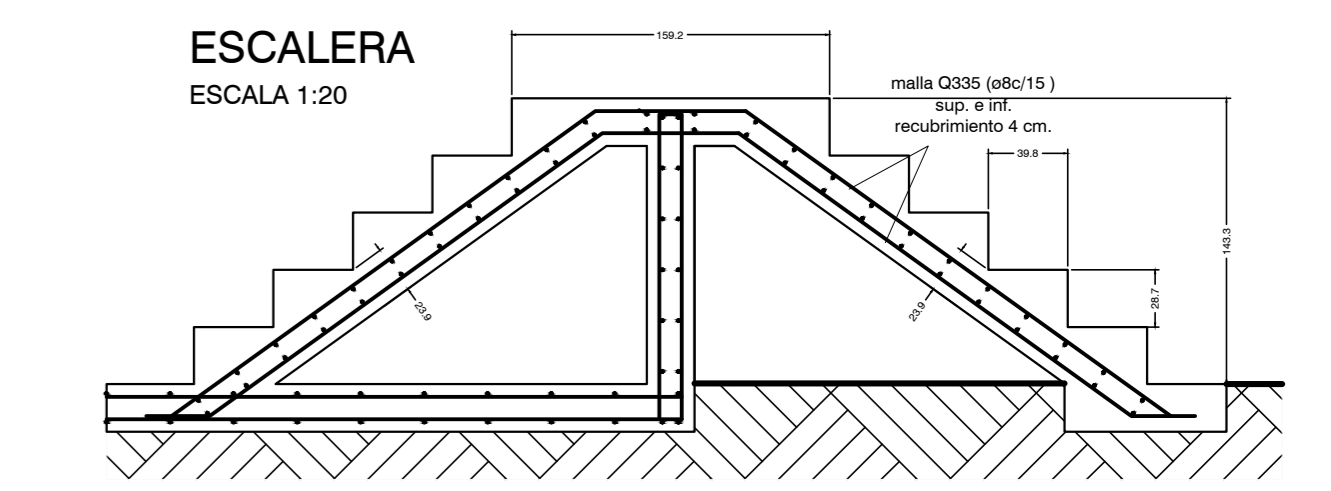

Desagüe hacia cámara colectora.

**CORTE**  
ESCALA 1:50

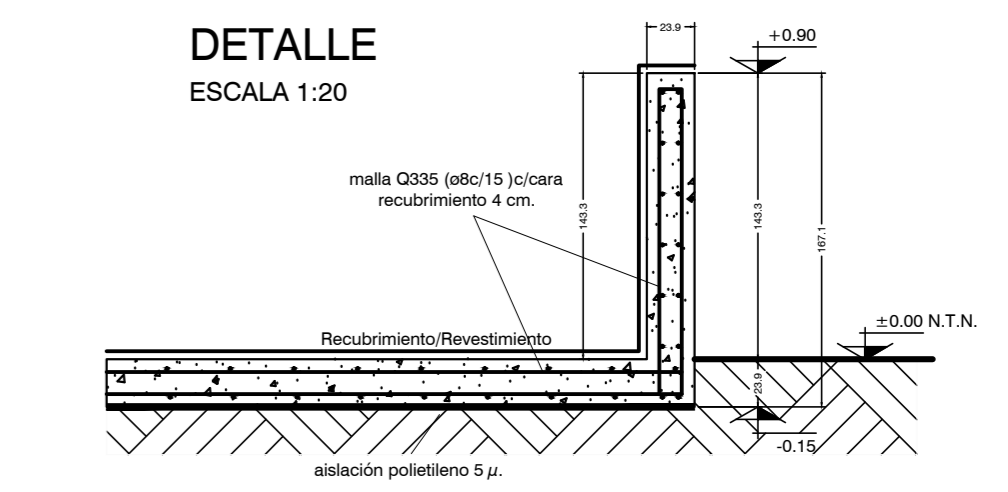
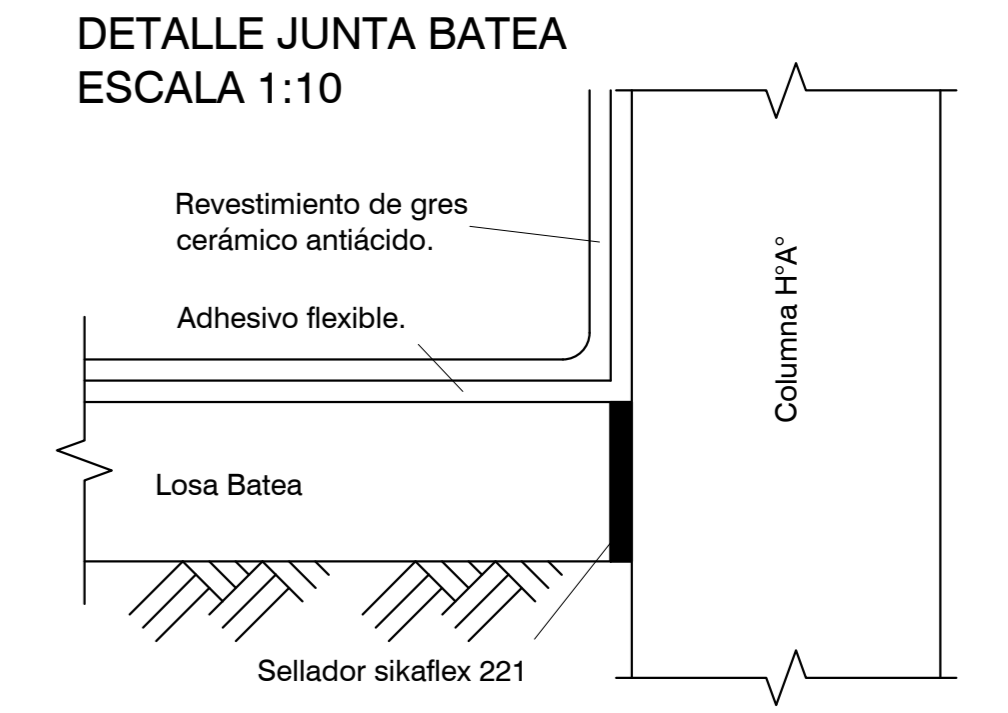
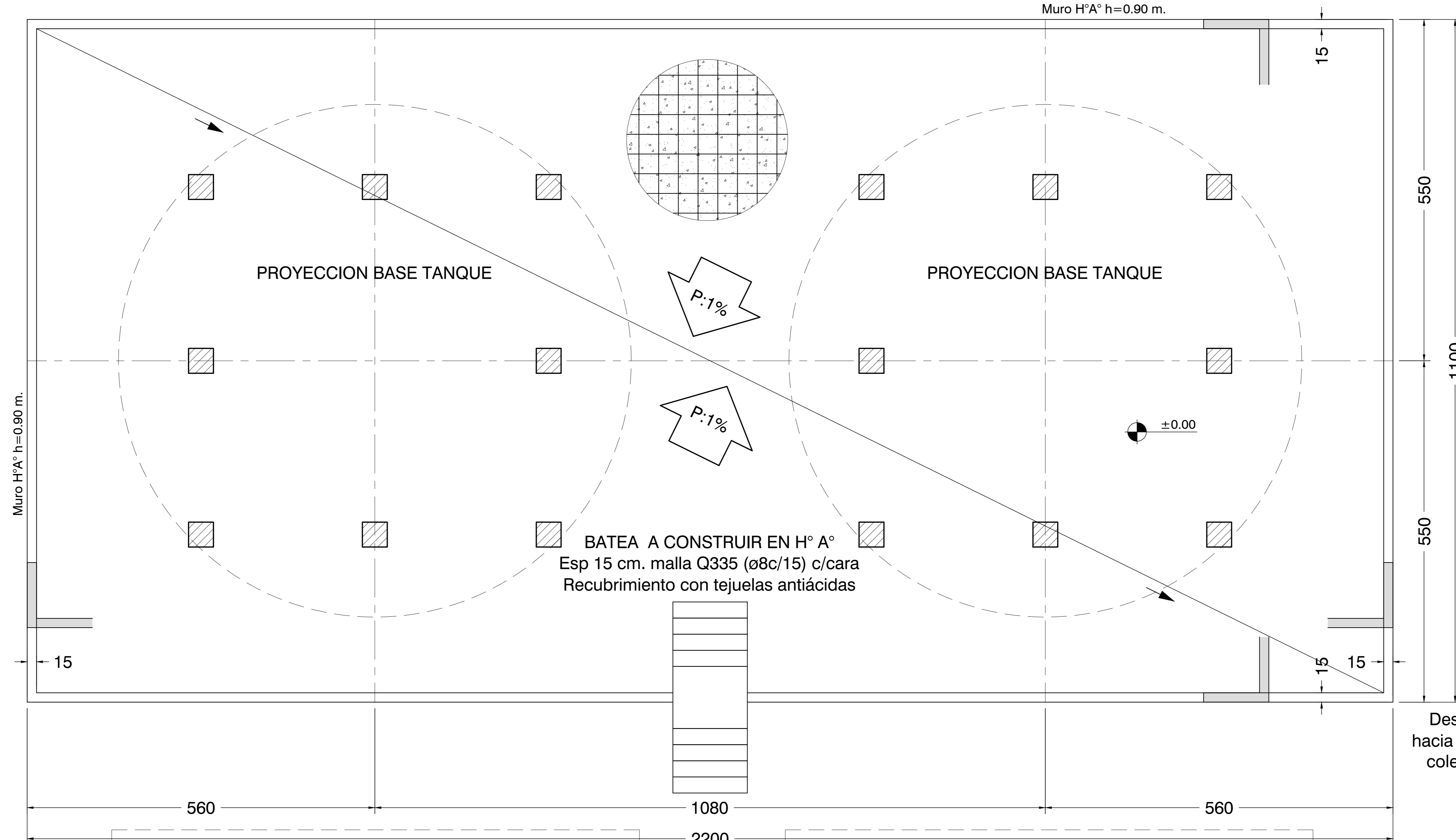
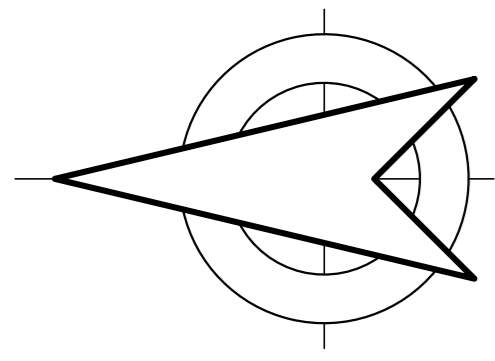